

Tunable graphene nanoribbon Bragg reflector

summarized and presented by

Edmund Merrow-Smith

551192@swan.ac.uk

Waveguides

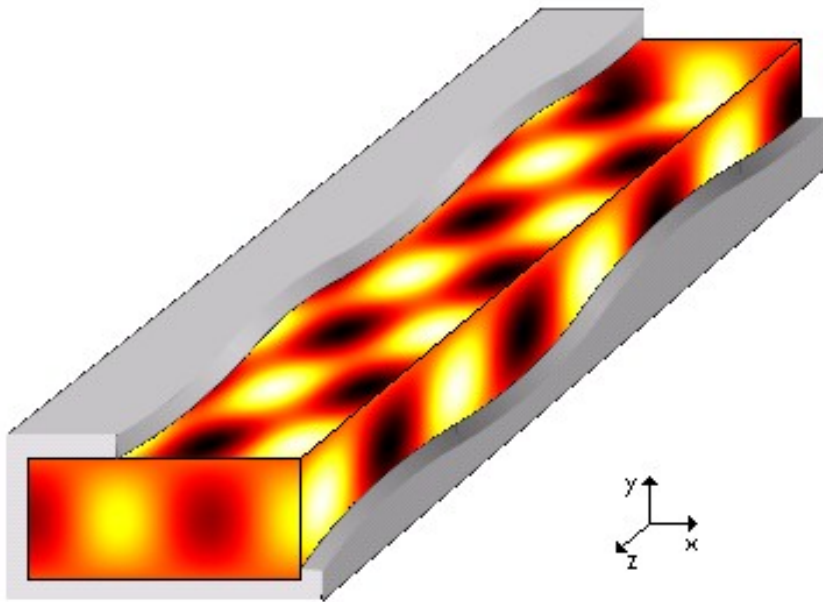

E_{\perp} components of the
transversal electric
(TE) wave in a
rectangular waveguide

$$E_z = 0$$

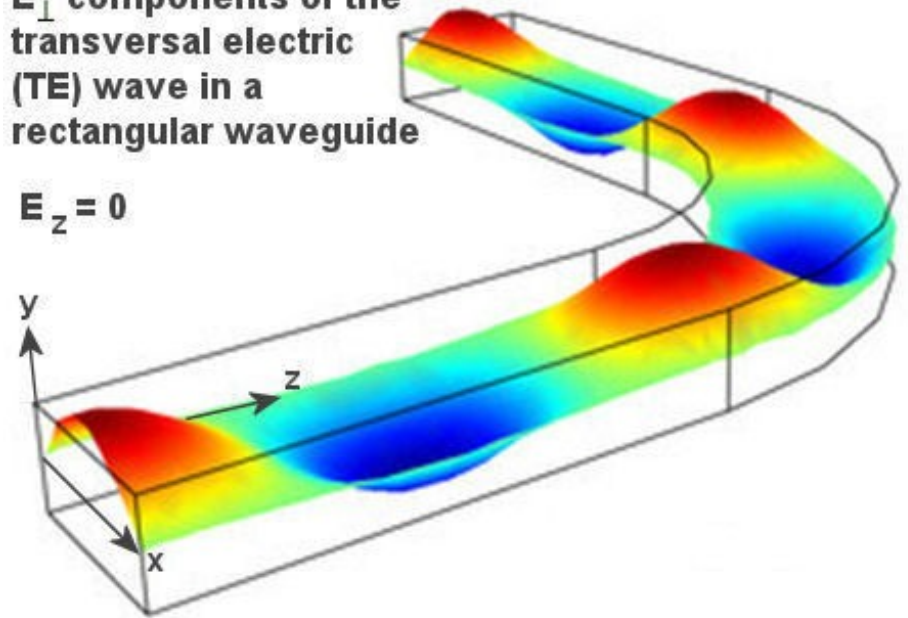

Fibre Optic Cables

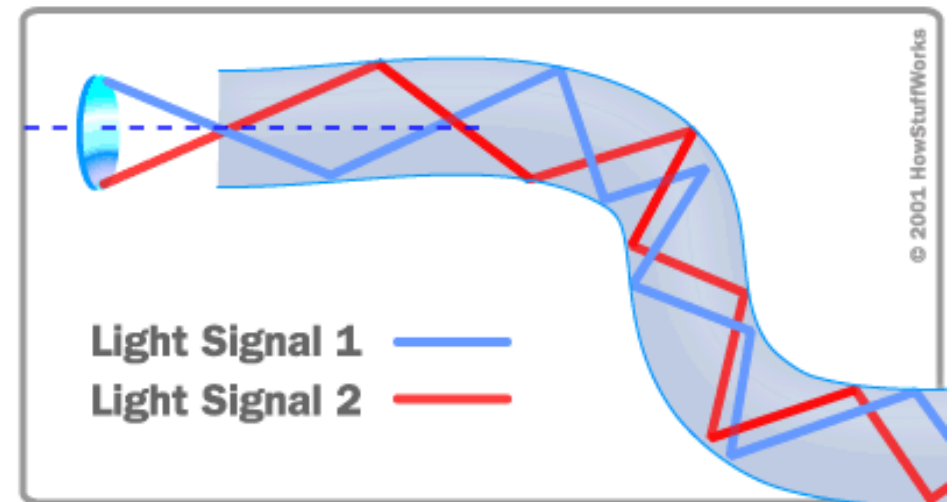
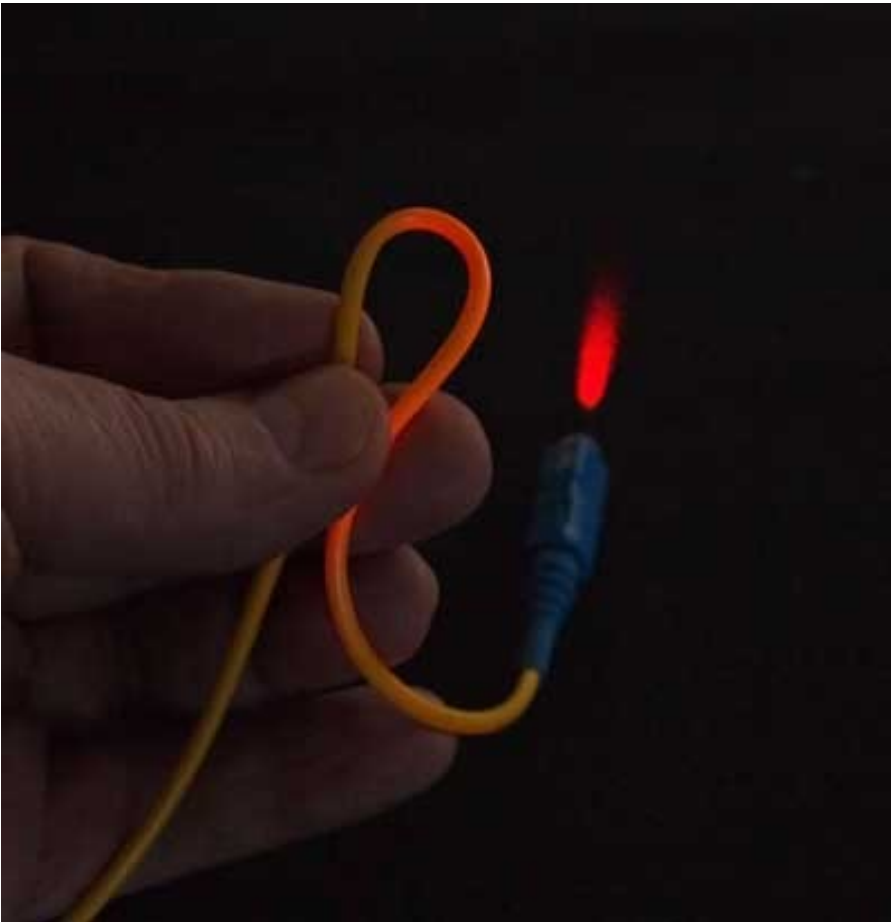

Microstrip waveguide - EM waveguide

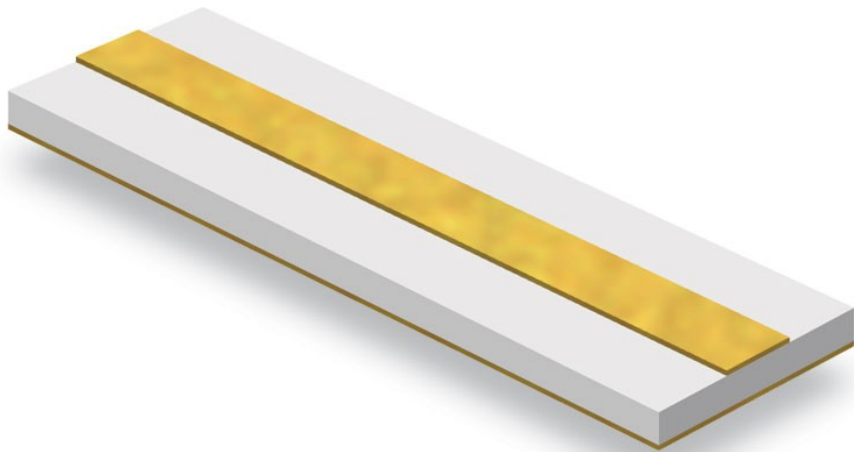

Graphene ribbon waveguide

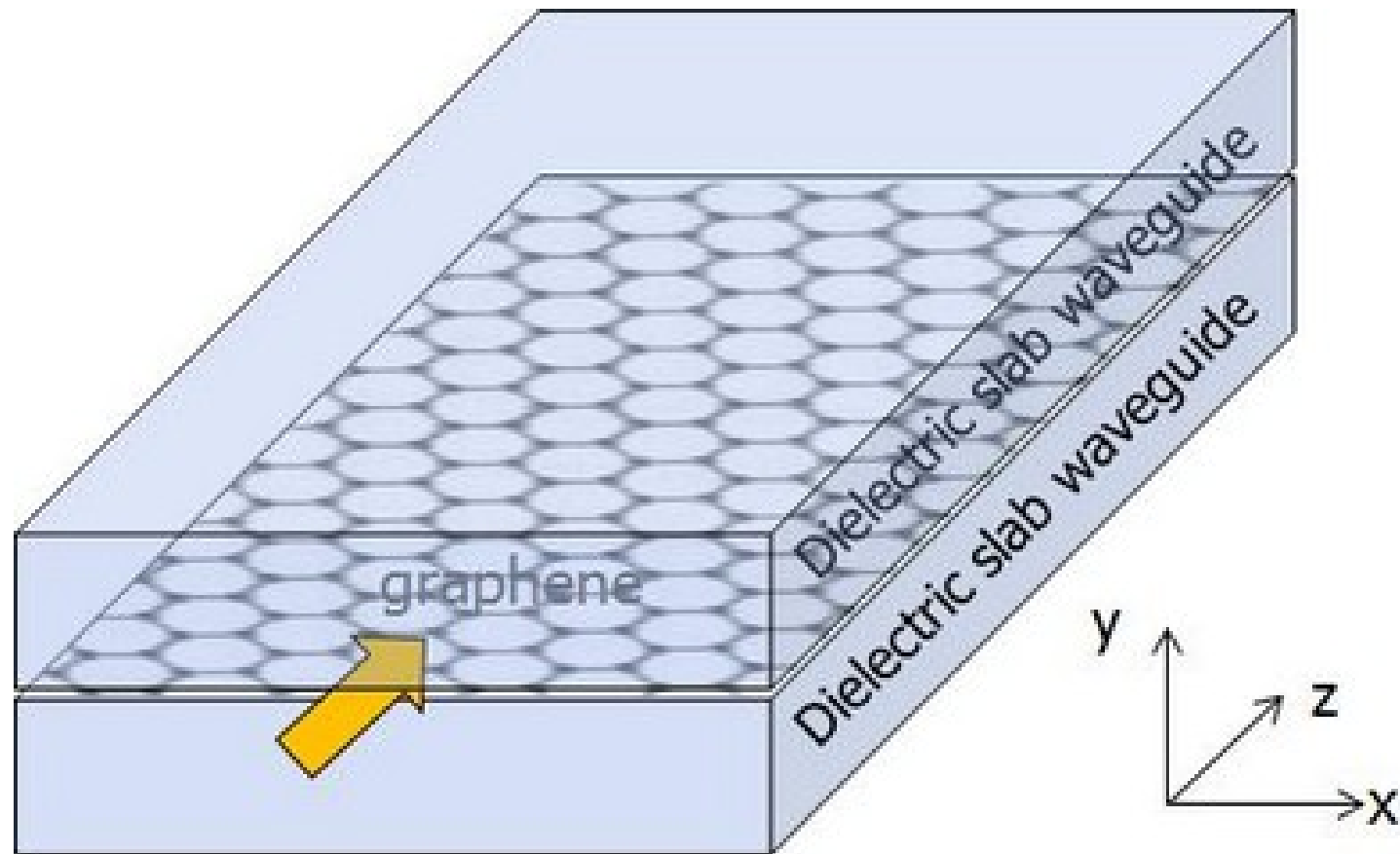

Surface Plasmon Polaritons

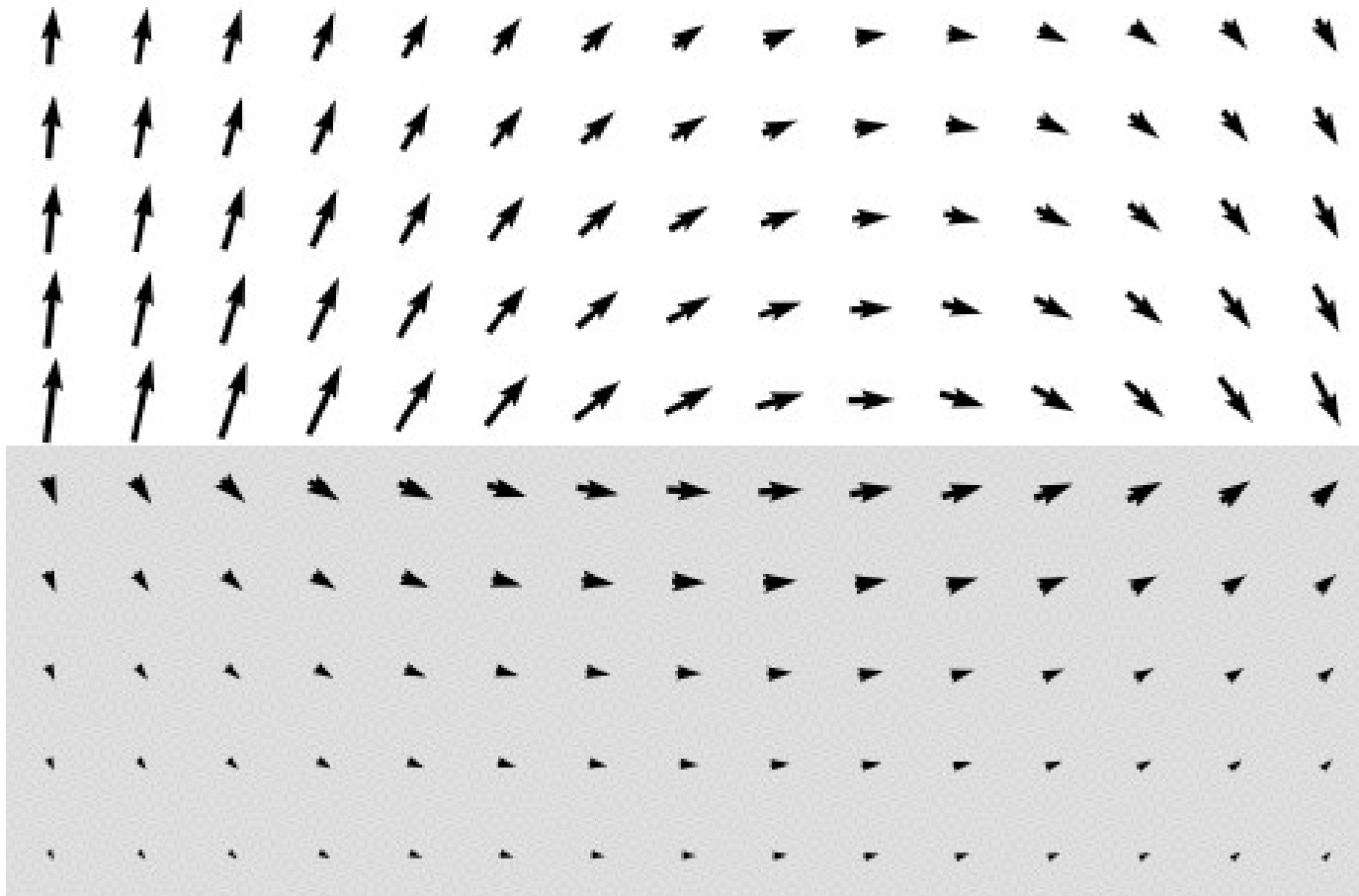

Tunable graphene nanoribbon Bragg reflector

Bragg's Law $n \lambda = 2 d \sin \theta$

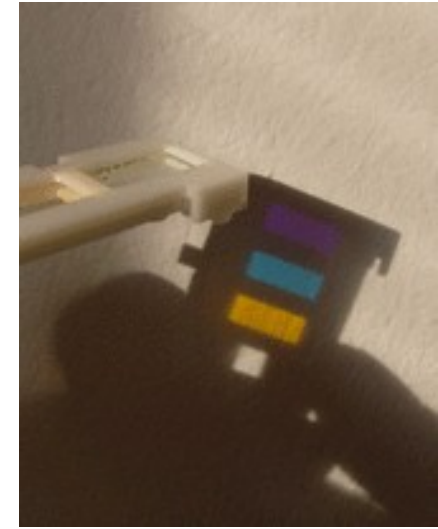
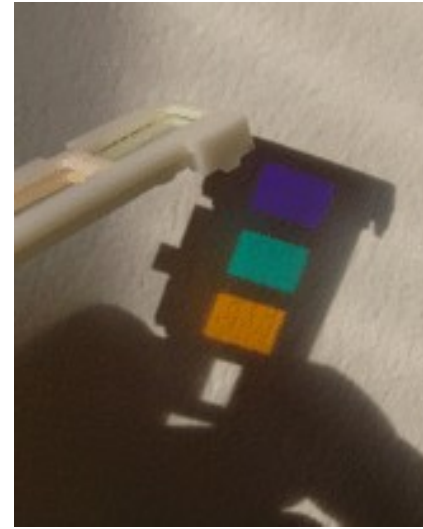
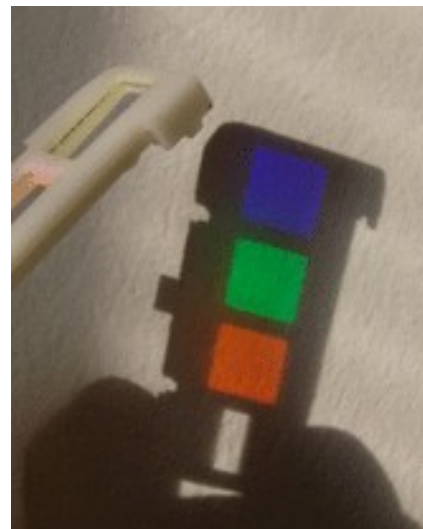
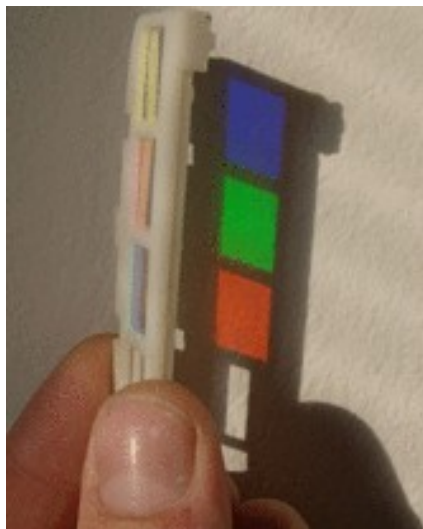
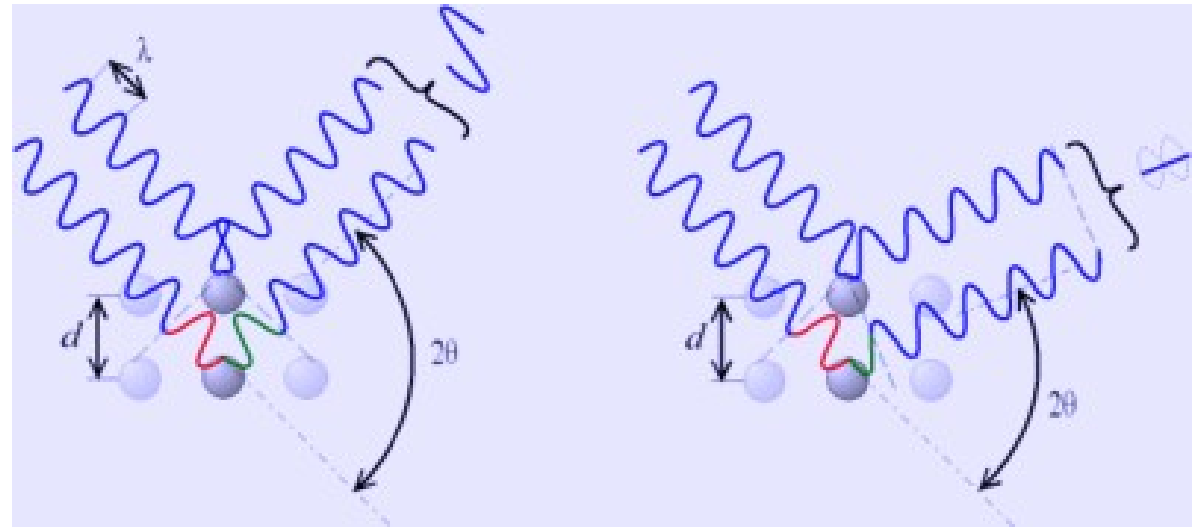

Bragg reflector

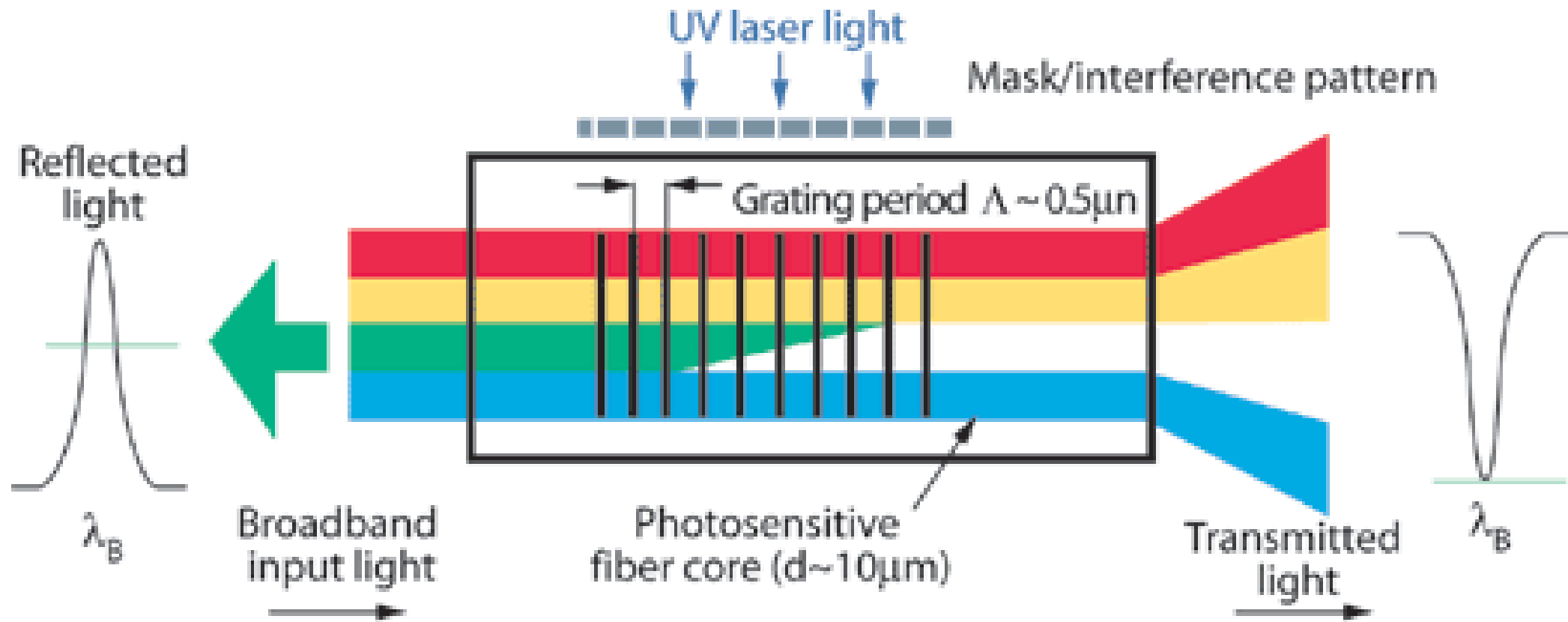

Source: Kayser-Threde GmbH

Bragg reflector

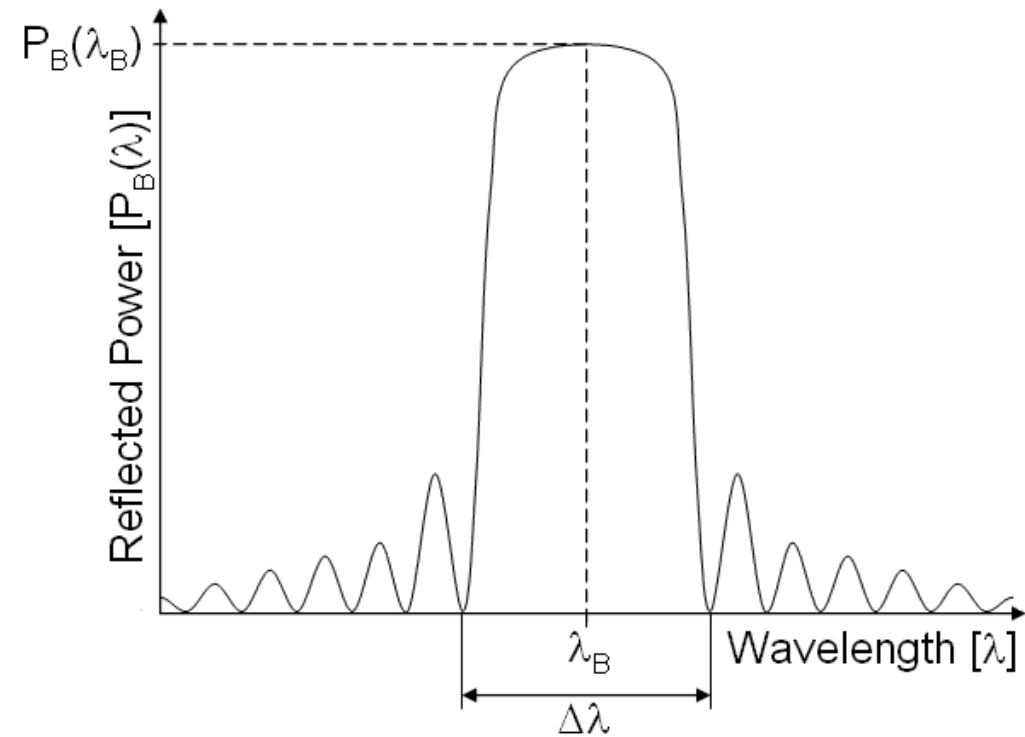
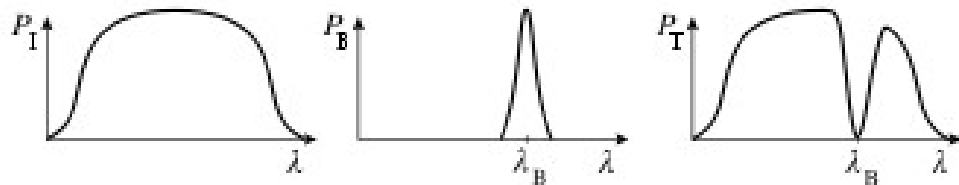
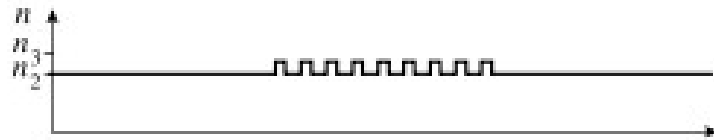
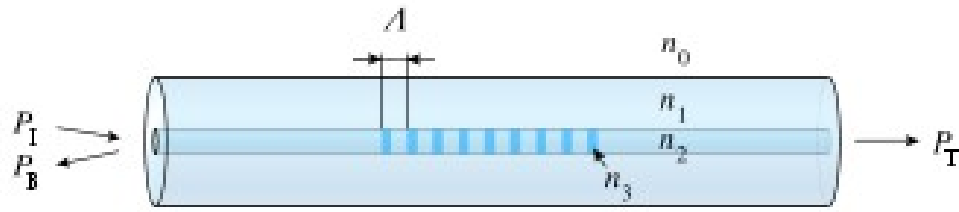

Graphene ribbon waveguide

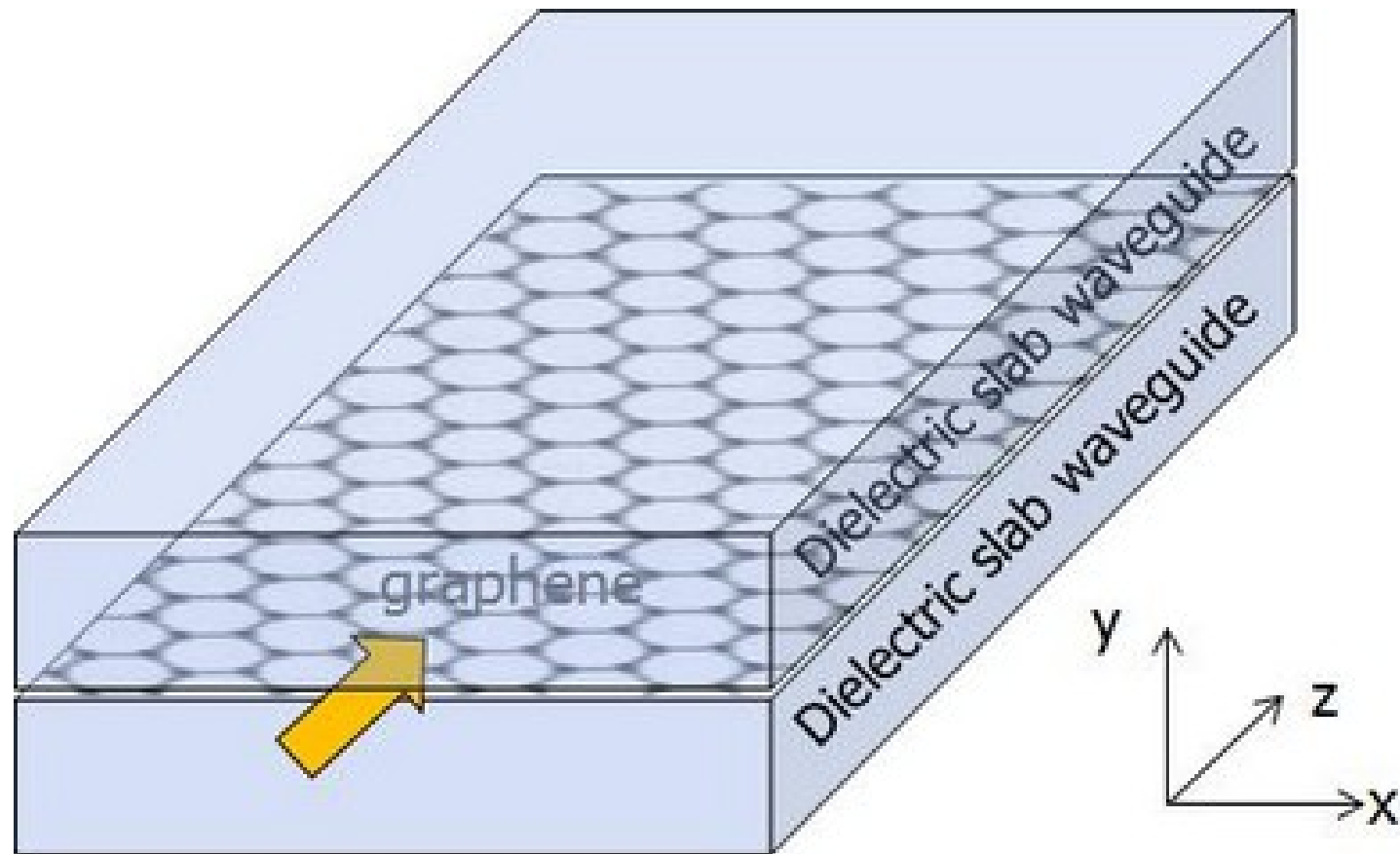

An ultra-compact tunable Bragg reflector based on edge propagating plasmons in graphene nanoribbon

Zhen-Rong Huang, Ling-Ling Wang, Meng-Dong He, Hong-Ju Li, Bin Sun, Jian-Qiang Liu and Xiang Zhai

Journal of Modern Optics, 2014
<http://dx.doi.org/10.1080/09500340.2014.989926>

Graphene ribbon Bragg reflector

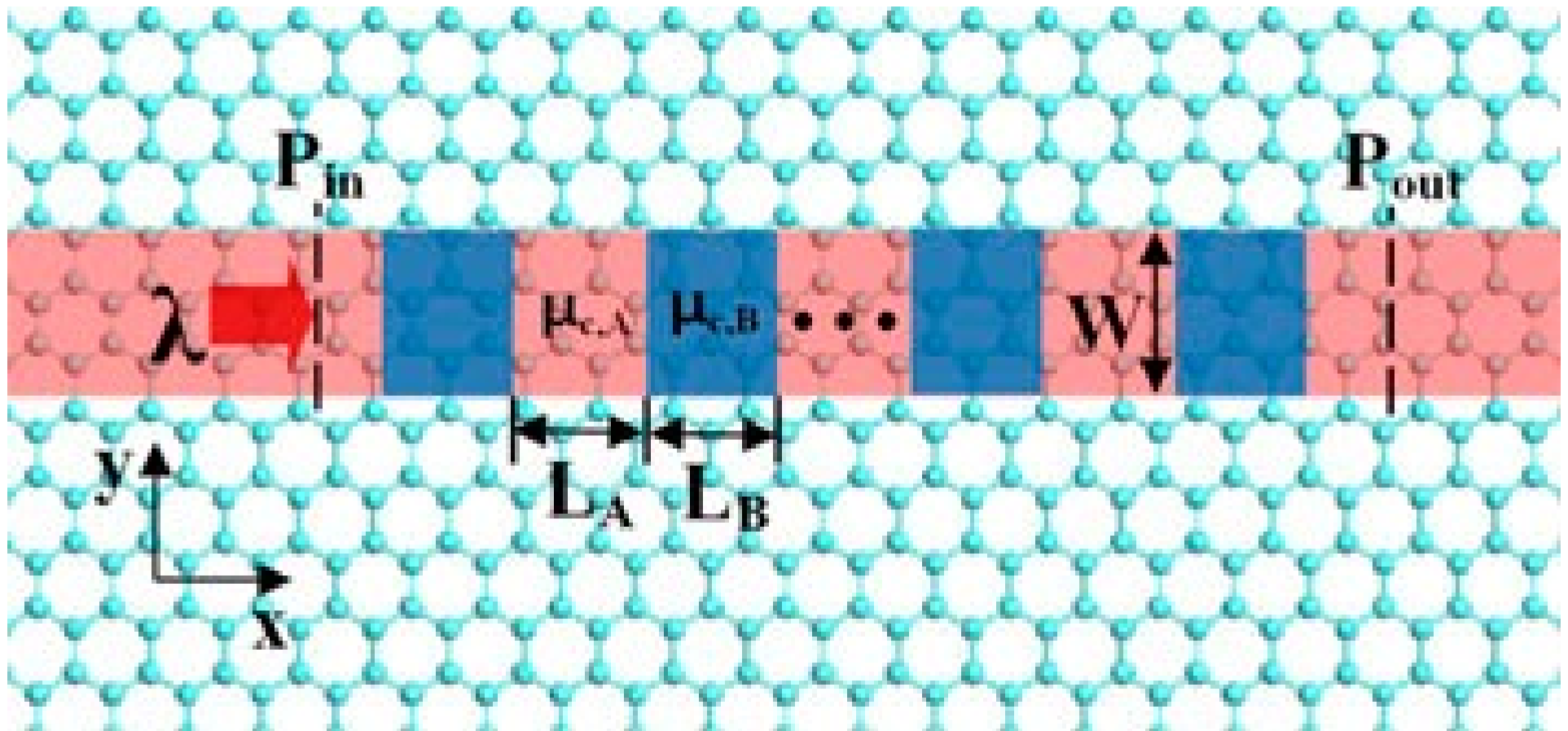

Tunable!

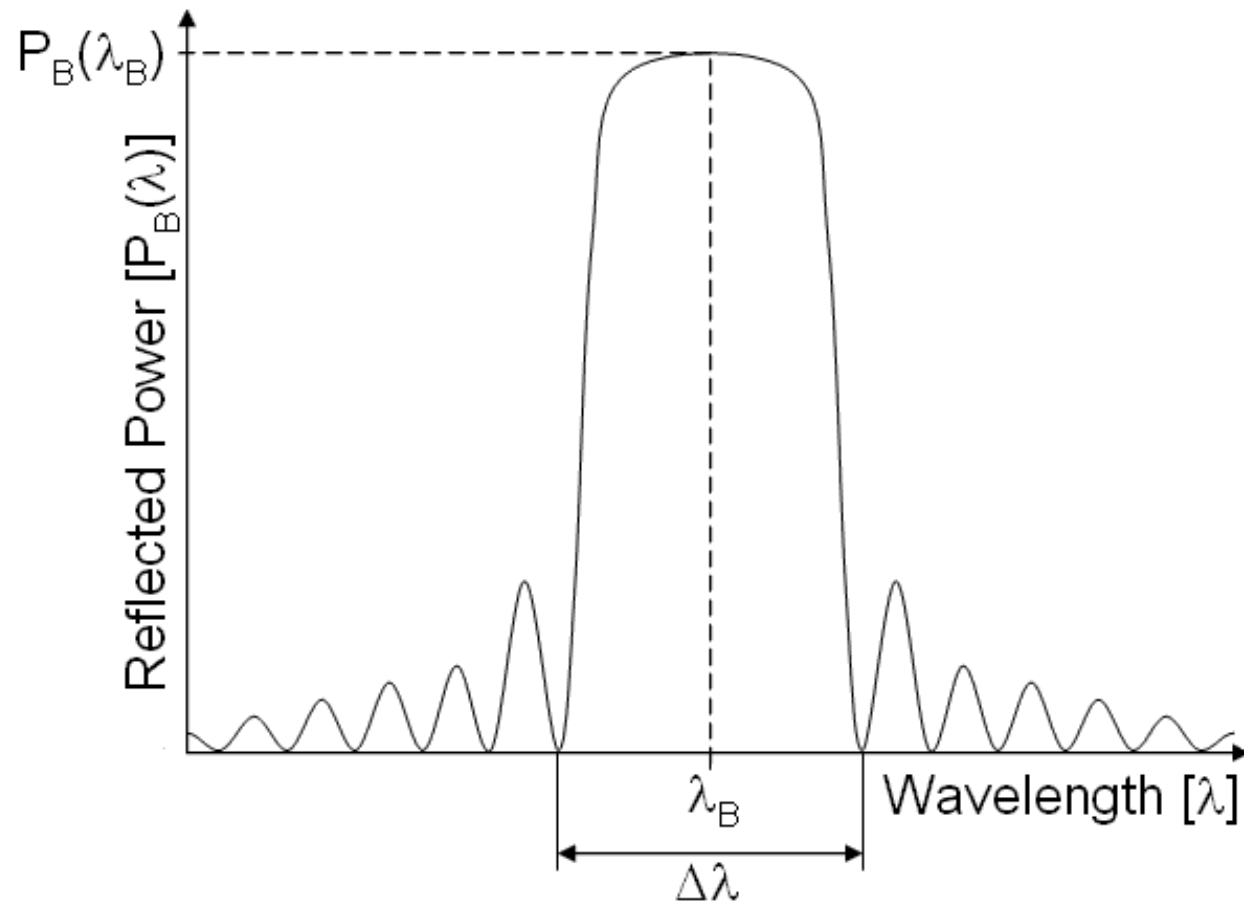

Tunable!

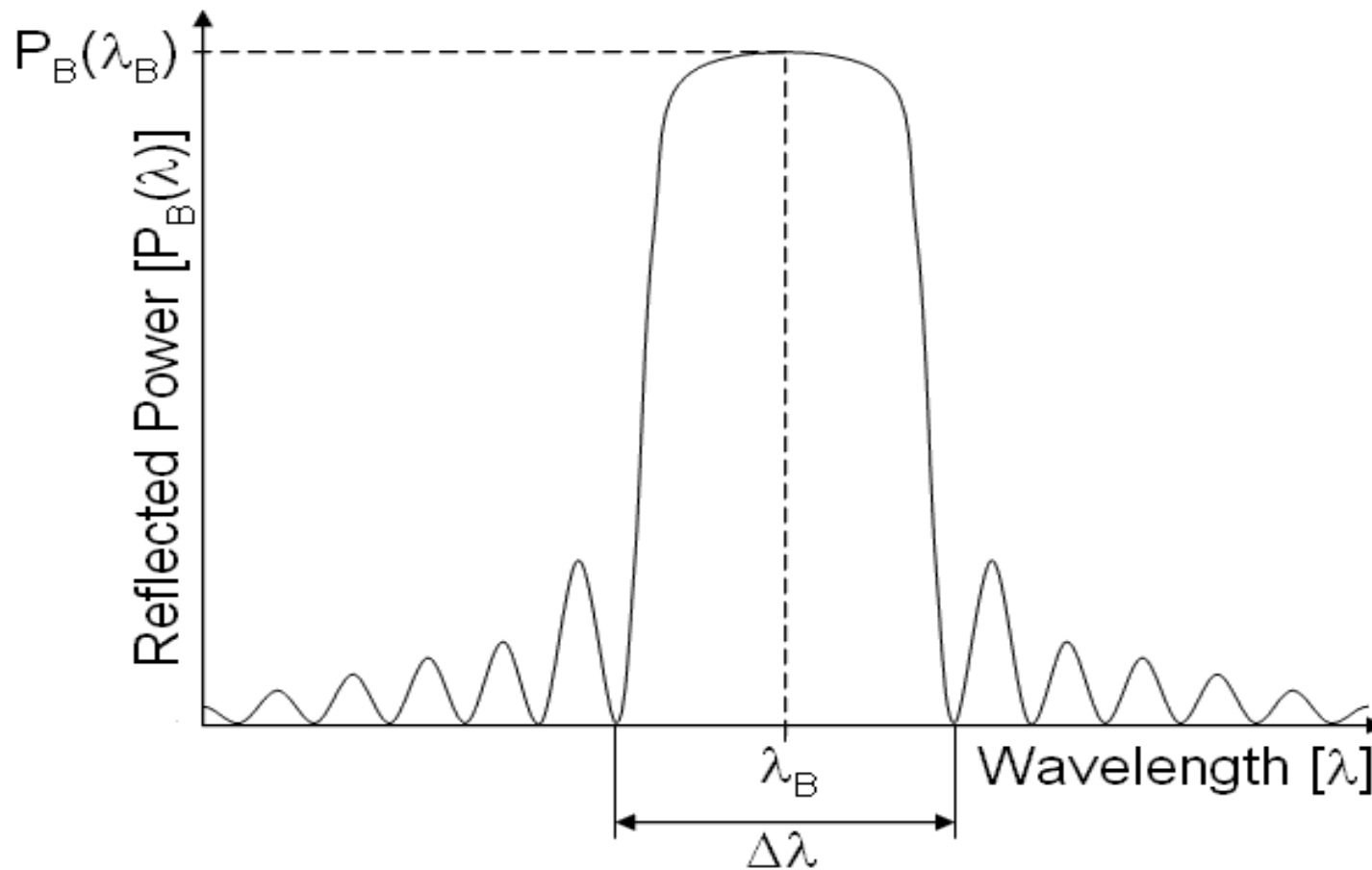

Tunable!

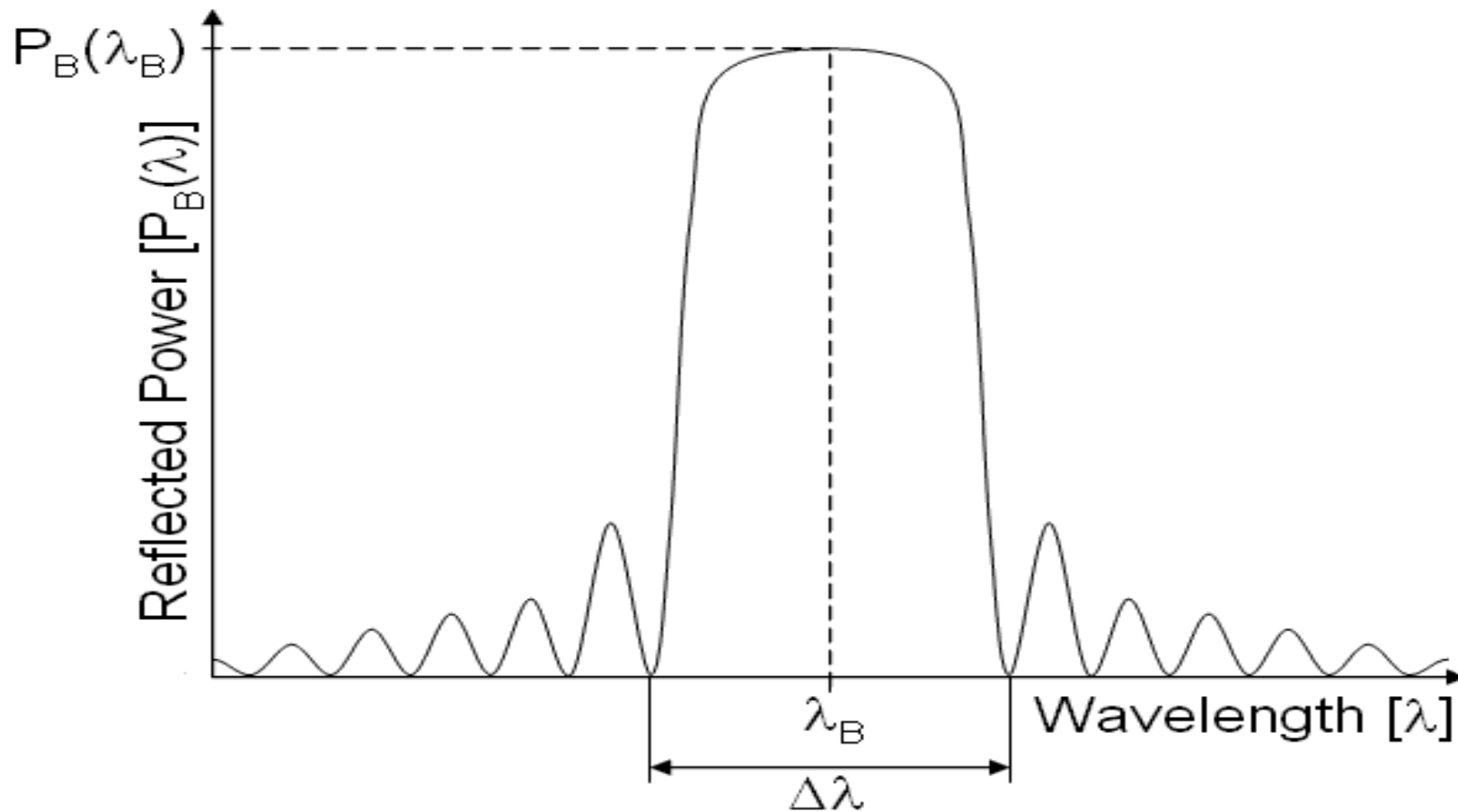

Uses?

- Good reflector
- Tunable
- Tiny
- Efficient
- Lasers
- Optical networks
- Optical Logic circuits?
(light computers?)

Bragg reflection laser

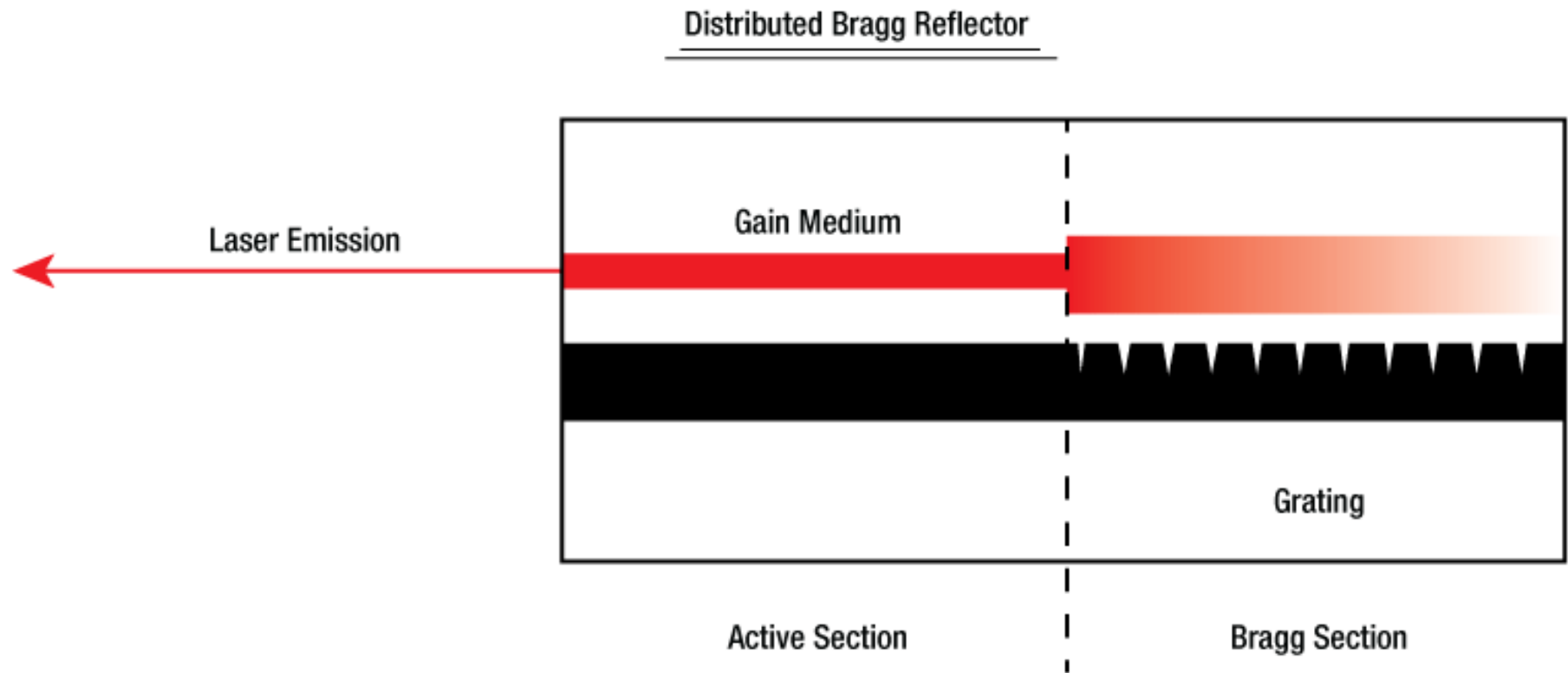

Optical Networks

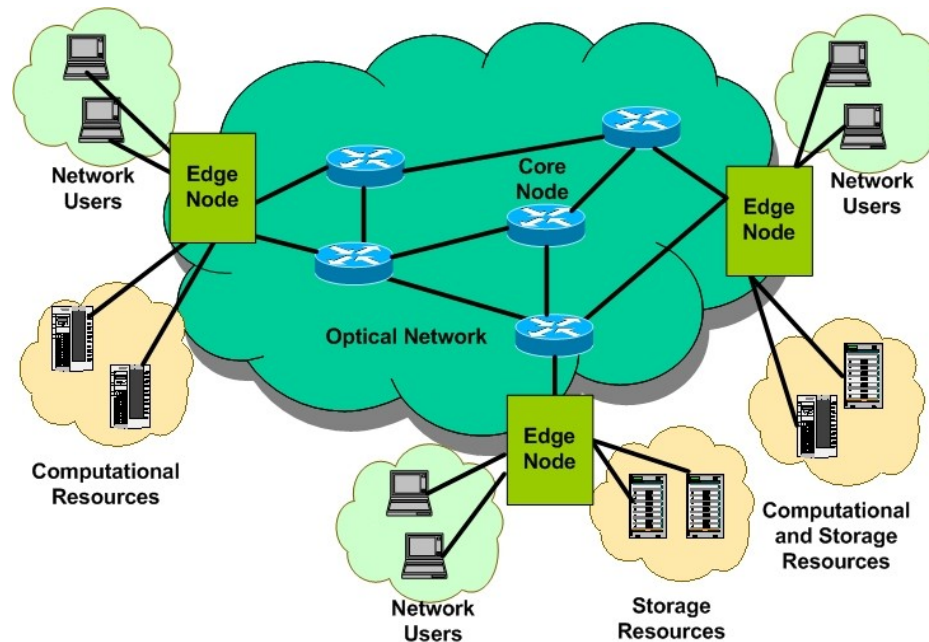
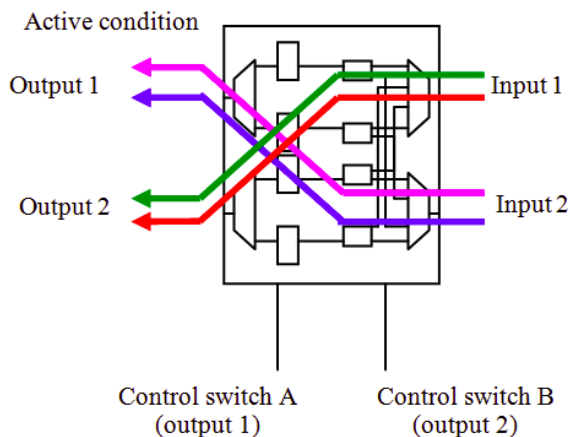
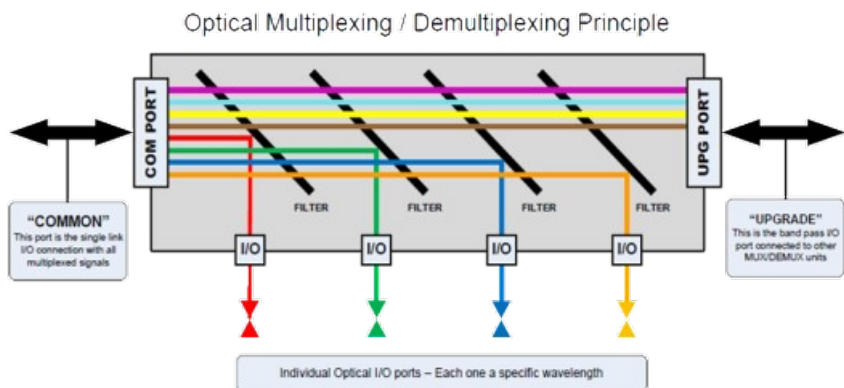

Optical Logic circuits? Light computers?

A	B	C	Y
0	0	0	
0	0	1	
0	1	0	
0	1	1	
1	0	0	
1	0	1	
1	1	0	
1	1	1	

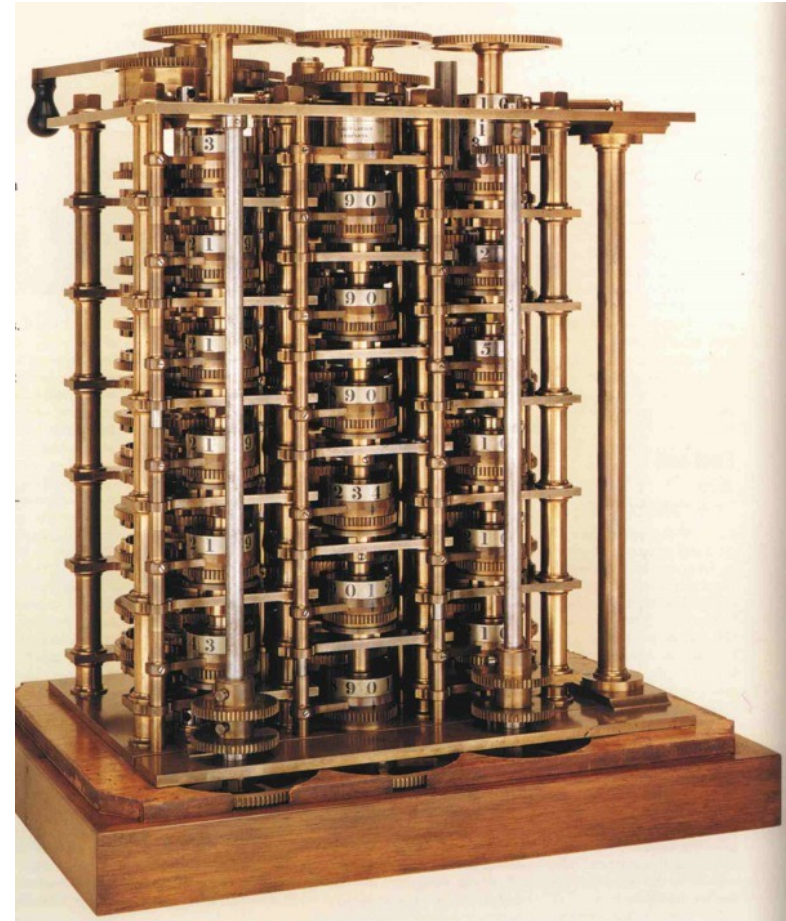
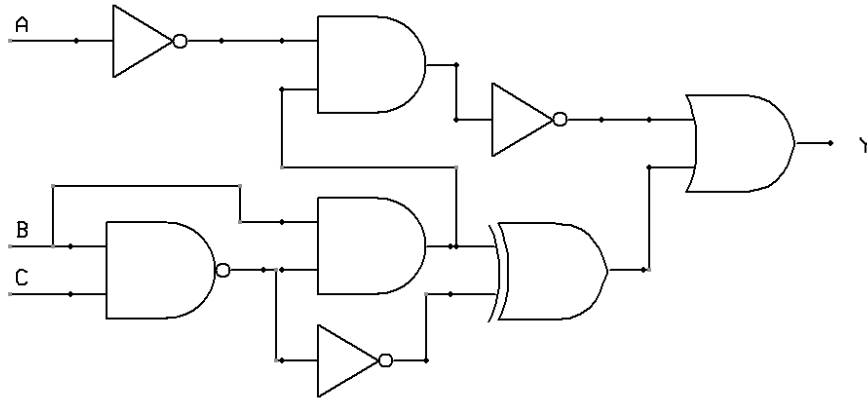

Thanks for listening

An ultra-compact tunable Bragg reflector based on edge propagating plasmons in graphene nanoribbon

Zhen-Rong Huang, Ling-Ling Wang, Meng-Dong He, Hong-Ju Li, Bin Sun, Jian-Qiang Liu and Xiang Zhai

Journal of Modern Optics, 2014
<http://dx.doi.org/10.1080/09500340.2014.989926>